

FRANCE
METAL
STEEL DOORS & FRAMES



**NOTHING FIGHTS FIRE
LIKE A STEEL DOOR**

 **Ceco Door**

ASSA ABLOY

Manufactured Under License





SETTING

NEW STANDARDS

FOR STEEL DOORS MANUFACTURING

Introduction

Famous Doors in Famous Places



NILE CITY



CITYSTARS

Where performance is of primary concern, France Metal can provide a choice of steel doors & frames to match the appropriate project demands.

This includes mobility, security and acoustic specifications, together with a full range of fire rated doors, tested and accredited by UNDERWRITERS LABORATORY (UL)

France Metal doors & frames are the perfect solution to your openings.

France Metal steel doors & frames range has been designed to meet the industries most enhancing standards of specification, making them ideally suitable for commercial projects.

فرانس ميتال الشركة الرائدة في مصر لتصنيع الابواب والحلوق المعدنية بأنواعها المختلفة ، وذلك بترخيص من كبرى الشركات الامريكية : CECO DOOR PRODUCTS

ويشمل انتاج شركة فرانس ميتال حلوق وابواب معدنية :

- مقاومة للحريق وعادية
- متساكنة ستيل
- مضادة للزلازل
- عازلة للصوت
- مزخرفة
- لغرف الاشعة السينية

كما أن منتجات شركة فرانس ميتال حاصلة على شهادة اختبار من معامل الـ Under Writers Laboratory (UL) وكبرى المعامل المتخصصة في مجال الحريق مما يجعل الابواب مطابقة لكود الحريق المصري والامريكي NFPA80



High-Tech Innovation & Creativity

Performance



▶ PHYSICAL ENDURANCE

Measures door assembly's ability to resist Deterioration resulting from expected usage.

TEST CONSISTS OF TWO PARTS:

SWING TEST (ANSI A250.4.94) Door
(ANSI A250.5.94) frame

Door is opened and closed a prescribed number of times.

TWIST TEST (ANSI A250.4.94) Door

Periodically throughout swing test, a 300 lb. load is applied to the upper lock edge corner to gauge the door's ability to resist permanent deflection.

▶ STRUCTURAL PERFORMANCE

Measures door assembly's ability to resist Static loads similar to those caused by high winds.

TEST-ASTM E330-90, "Structural Performance by Uniform Static Air Pressure Difference"

▶ SECURITY

Measures Door assembly's ability to restrain, delay and frustrate certain burglar attacks. "Attacks" as defined in NILECJ standard.

TEST-ASTM F476-76. The Door assemblies tested conform to classification 40.

▶ CONFORMANCE TO INTERNATIONALLY ACCEPTED SPECIFICATIONS AND STANDARDS

When properly specified, France Metal doors and frames will conform to the document requirements of the recognized agencies listed below;
CEGS-08110: Steel Doors and Frames – Guide Spec. for Military Construction – Army Corps of Engineers.

ANSI A250.8: Recommended Specs. For Steel Doors & Frames, SDI.

HMMA861: Commercial Hollow Metal Doors and Frames, NAAMM.

ANSI A115: Standard Specs. for Door and Frame Hardware Preparation.

ANSI/NFPA 101: Life Safety Code.

ANSI/NFPA 105: Installation of Smoke and Draft Control Assemblies.

ANSI/NFPA 80 : Fire Doors & Windows.

ANSI/NFPA 252: Fire Test of Door Assemblies.

ANSI/NFPA 257: Fire Test of Window Assemblies.

UL9 : Fire Test of Window Assemblies.

UL 10B : Fire Test of Door Assemblies.

UL 10C : Positive Pressure Fire Test of Door Assemblies.

UL 752 : Bullet Resistant Equipment.

UBC 7-2: Fire Test of Door Assemblies.

UBC 7-4: Fire Test of Window Assemblies.

BS 476 Part 22-'87: Fire Test on Bldg. Mtis' and Structures.



FRANCE METAL STEEL DOORS





Steel Frames

For Doors & Windows

FRAME SPECIFICATIONS

STANDARD FEATURES:

- Cold rolled steel sheets conforming to ASTM A366
- Sheet Thickness: 1.5 mm, Level (2), Heavy Duty
- Jamb depth 150 mm.
- Knock down corners.
- Existing opening anchors (EO/N) for masonry applications. Z-anchors (MSZ) for dry wall applications.
- 4.2 mm thick steel hinge reinforcement
For template mortise hinges. 4.5" (114.3 mm) height.
- Plaster guard box @ back of hardware cut out
- 3 silencers (Rubber Mutes) @ single leaf frame lock jamb. OR 2 silencers (Rubber Mutes) @ double leaves frame head.
- Finished in Epoxy Primer Paint, factory applied.
Act as a base coat for field applied finish coat.

OPTIONS:

- Fire rated (UL) Label up to 3 hours.
- Bullet resistant (UL) Label up to level 4.
- Hot - dipped galvanized steel sheets conforming to ASTM A526 or A642 & A525.
- Sheet thickness:
 - Level (1), Standard duty, 1.2 mm thick
 - Level (3), Extra heavy duty, 2.0 mm thick
 - Level (4), Maximum duty, 2.5mm thick
- Jamb Depth up to 350 mm.
- Welded corners with temporary bottom spreader bars.
- Fixing Anchors:
 - MT-WMA-EO/Tube-WSZS-SFA-SLFA
- Perimeter weather & cold smoke gasket @CFWK profiles.
- 4" (101.6 mm) or 5" (127 mm) height hinge reinforcement.
- Electric strike preparation
- Four Sided for Access Panels.
- Glazing Beads for Fixed type Windows.
- 30 mm stop for Fixed louvers.



Single Rabbet



Single Rabbet
Weather Kerf



Double Rabbet



Double Rabbet
Weather Kerf



Double Egress



Frame Nomenclature

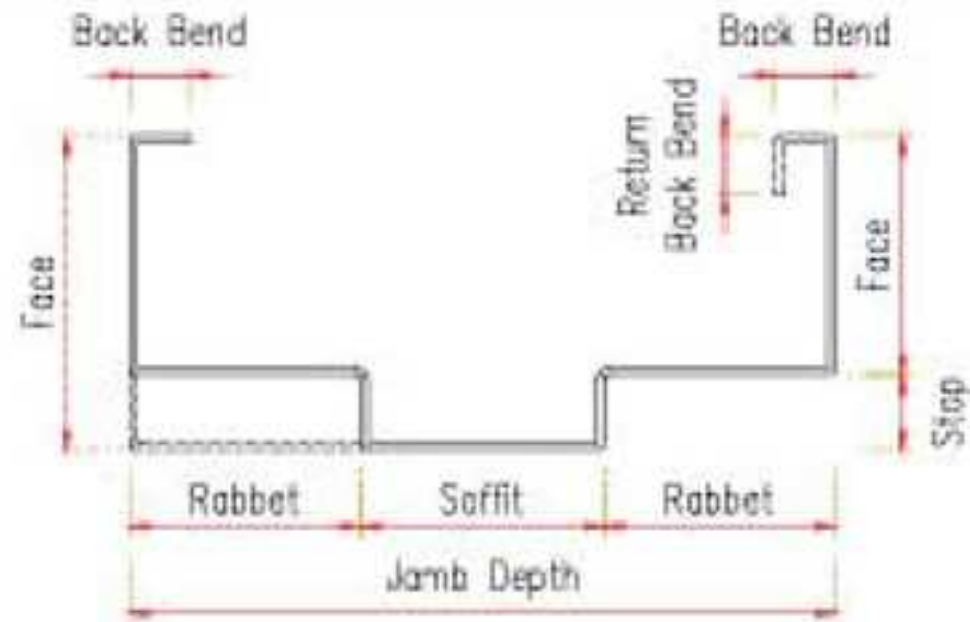

Frame Profile

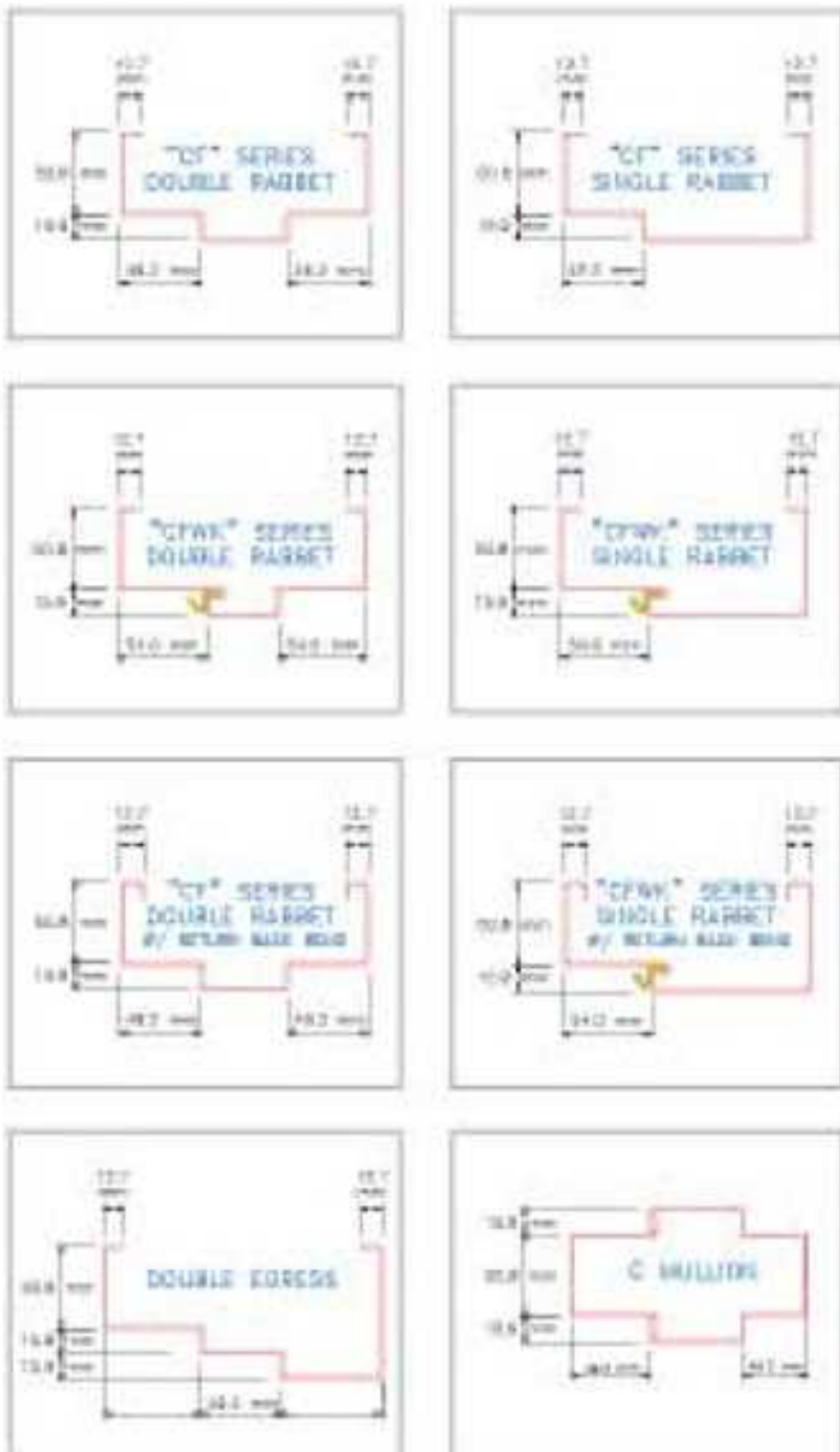

Frame Fixing Anchors

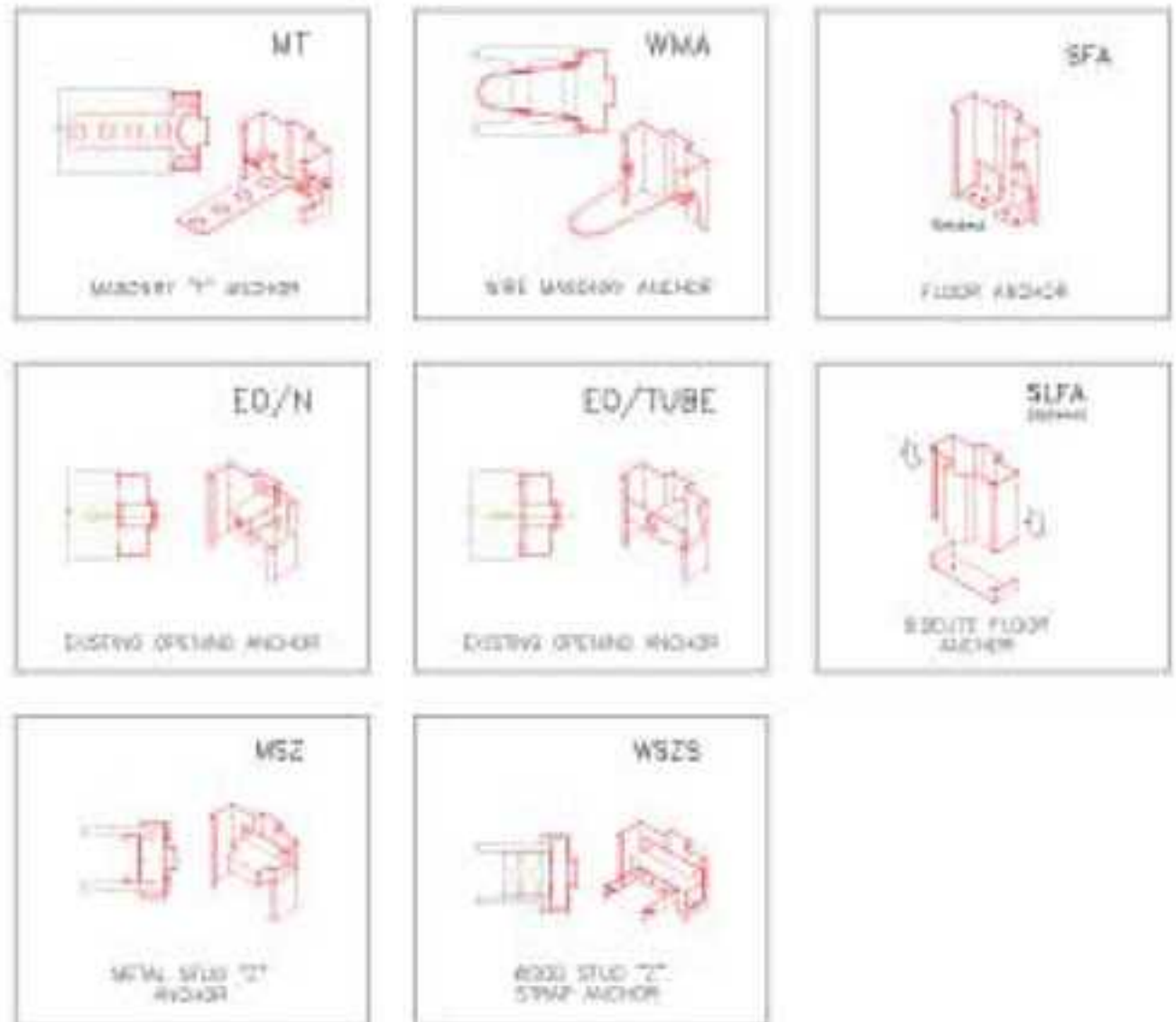



Safety is our Concern





STANDARD FEATURES

- Cold rolled steel sheets conforming to ASTM A366 (except MADERA / STAINLESS STEEL Doors)
- Face sheet thickness: 1.0 mm, level (2), heavy duty
- Mechanically interlocked face sheets, with edge seams.
- Over all door thickness: 45 mm.
- Lock edge beveled 1/8" in 2" (1:16)
- 4.2 mm thick steel hinge reinforcement.
For full mortise type hinge of 4.5" (114.3 mm) height.
- Flush top channel.
- Inverted bottom channels.
- Finish: Epoxy primer paint, factory applied.
Act as base coat for field applied finish coat.
- Tested for one Million open / close cycles.

OPTIONAL FEATURES

- Fire rating  label Up to 3 hours.
- Hot dipped galvanized steel sheets conforming to ASTM A526 or A642 & A525.
- Sheet thickness:
Level (1), Standard duty, 0.8 mm.
Level (3), Extra heavy duty, 1.2 mm.
Level (4), Maximum duty, 1.5 mm.
- 4" (101.6 mm) or 5" (127 mm) height hinge reinforcement.
- Magnetic lock preparation.
- Electric strike preparation.
- Seamless edges.

FIRE RATING

- Only doors carrying physical  label are considered fire rated.
- Labeled openings include door, frame and hardware.
The effectiveness of the entire opening as a fire barrier may be destroyed if any component is omitted or a non labeled component is used.
- Labeled fire doors have been tested for the fire endurance and hose stream test in accordance with NFPA 80, NFPA 252 and UL 10b.
- Labeled fire door must be installed with approved labeled hardware. For exact HW requirements refer to NFPA 80 and NFPA 101
- Louvers in fire rated doors, must be FUSIBLE LINK type. not larger than 24" x 24"
- Glass in fire rated doors must be  labeled type.
Of size not exceeding  limits.

Steel Doors

Doors Available Designs

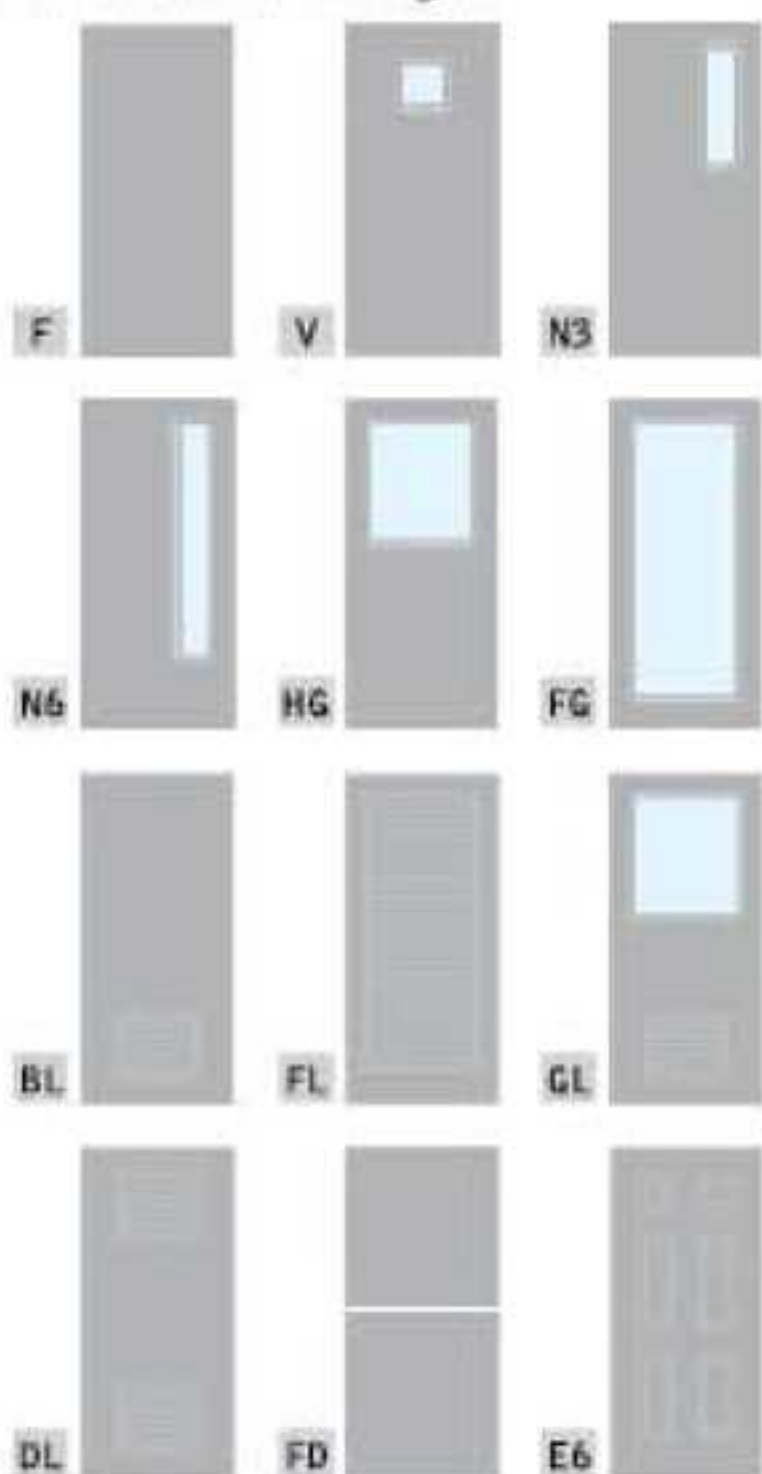

STEEL DOOR ACCESSORIES Vision Panels - Louvers





Regent

Simplest Solution to Close Openings

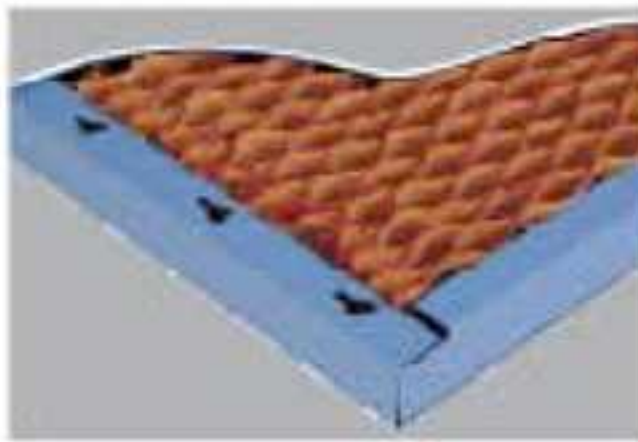

Door Characteristics

- Thermal Insulation Performance: R – Factor = 2.44
U – Factor = 0.41
- Sound Insulation Performance : STC = 32

Internal Core:

- Kraft-Honey Comb Core. Provides structural strength and flatness.
- Curtain coated contact adhesive for permanent pressure bond and rust prevention

Medallion

Light Design for High Frequency Traffic & Sound Insulation



Door Characteristics

- Thermal Insulation Performance: R – Factor = 2.38
U – Factor = 0.42
- Sound Insulation Performance : STC = 41

Internal Core:

- Vertical Steel Stiffeners 0.8 mm thick, extending full door height. 150 mm apart, along leaf width. Spot welded to face sheet not more than 125 mm of centers. Fiber Glass in Fill.
- Optional In Fill : ROCKWOLL





Security, Strength & Beauty



Madera

The Look of WOOD, The Security of STEEL



Door Characteristics

- Thermal Insulation Performance: R – Factor = 14.97
U – Factor = 0.067
- Sound Insulation Performance : STC = 26

Standard Features:

- Galvanized, Wood grain, Engraved Steel.
- Foamed Polyurethane Core, chemically bonded to door face sheets For total surface support. Impact resistant.
- Factory Pre-Finished Stain Coat, over stainable base coat. Tough clear finish coat with UV protection.

Size Limitation:

- FLUSH Designs:
 - Width: 600 to 1050 mm
 - Height: 2000 to 2400 mm
- EMBOSSED 6-PANEL Designs:
 - Width: 815 to 915 mm
 - Height: 2030 to 2130 mm



Imperial

The lightest in weight, the highest in insulation



Door Characteristics

- Thermal Insulation Performance: R – Factor = 14.97
U – Factor = 0.067
- Sound Insulation Performance : STC = 26

Internal Core:

- Foamed Polyurethane, chemically bonded to door face sheets for total surface support. Impact resistant.

• SPECIAL APPLICATION DOORS

Stainless Steel Tech

The right solution for health care industries

Door Characteristics

- Thermal Insulation Performance : R – Factor = 14.97
U – Factor = 0.067
- Sound Insulation Performance : STC = 26

Standard Features:

- Stainless steel sheets – Grade 304.
- Foamed Polyurethane Core, chemically bonded to door face sheets For total surface support. Impact resistant.
- Hair line matt finish.

Options:

- Face sheets: Stainless steel – Grade 316.
- Stainless steel hinge reinforcement.
- Seamless Edges (Face sheet 1.5 mm thick ONLY).





• SPECIAL APPLICATION DOORS



Anti Bullet

The simplest way to stop bullet attack.

	Level 3	Level 4
Rating	Super Power Small Arms	High Power Rifle
Firearms	.44 Magnum Revolver	30-06 Sporting Rifle
Barrel Length	6 1/2" (165)	—
Bullet Type	Soft Point 240 Grain	Spitzer 220 Grain
Muzzle Velocity	1470 Fps	2523 Fps
Muzzle Energy	1150 Ft-lb	3102 Ft-lb

Door Characteristics

- Effective to level 4: 30-06 rifle
- Tested in accordance with UL 752.

Internal Core:

- Concealed armor, flush faces armor plate thickness, vary with bullet resistance level.
- Foamed Polyurethane Core, chemically bonded to door face sheets for total surface support. Impact resistant.

TESTED IN CONFORMANCE WITH UL752 FOR THESE WEAPONS



For X-Ray Rooms Doors

Consult Our Tech.& Sales Office

Steel Doors Basics



Doors Handing Legend

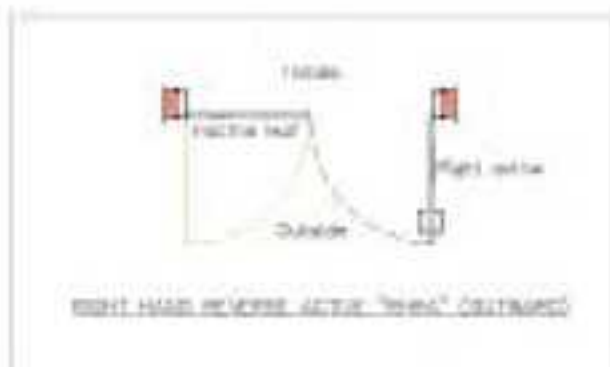
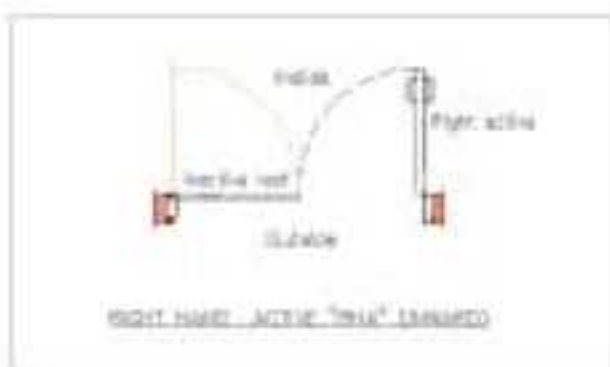
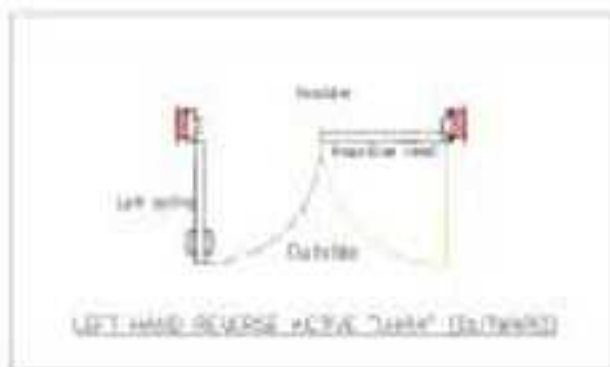
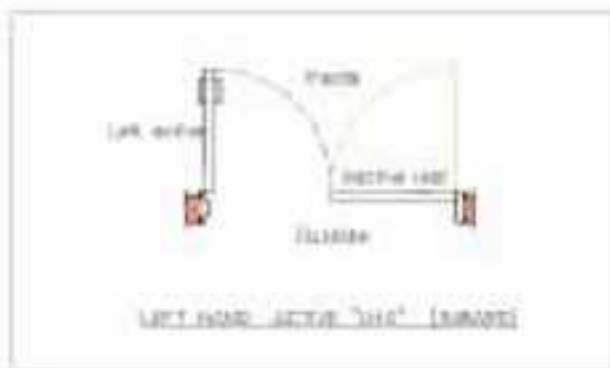
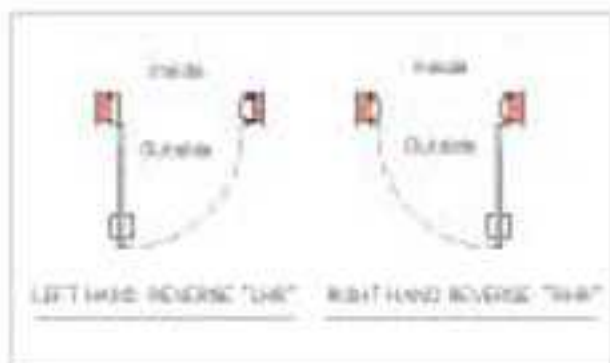
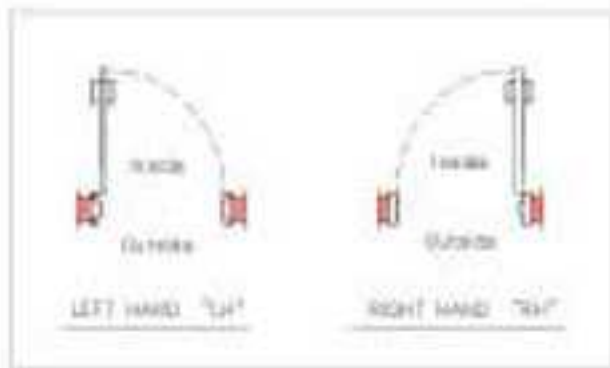

Frame Door Clearance

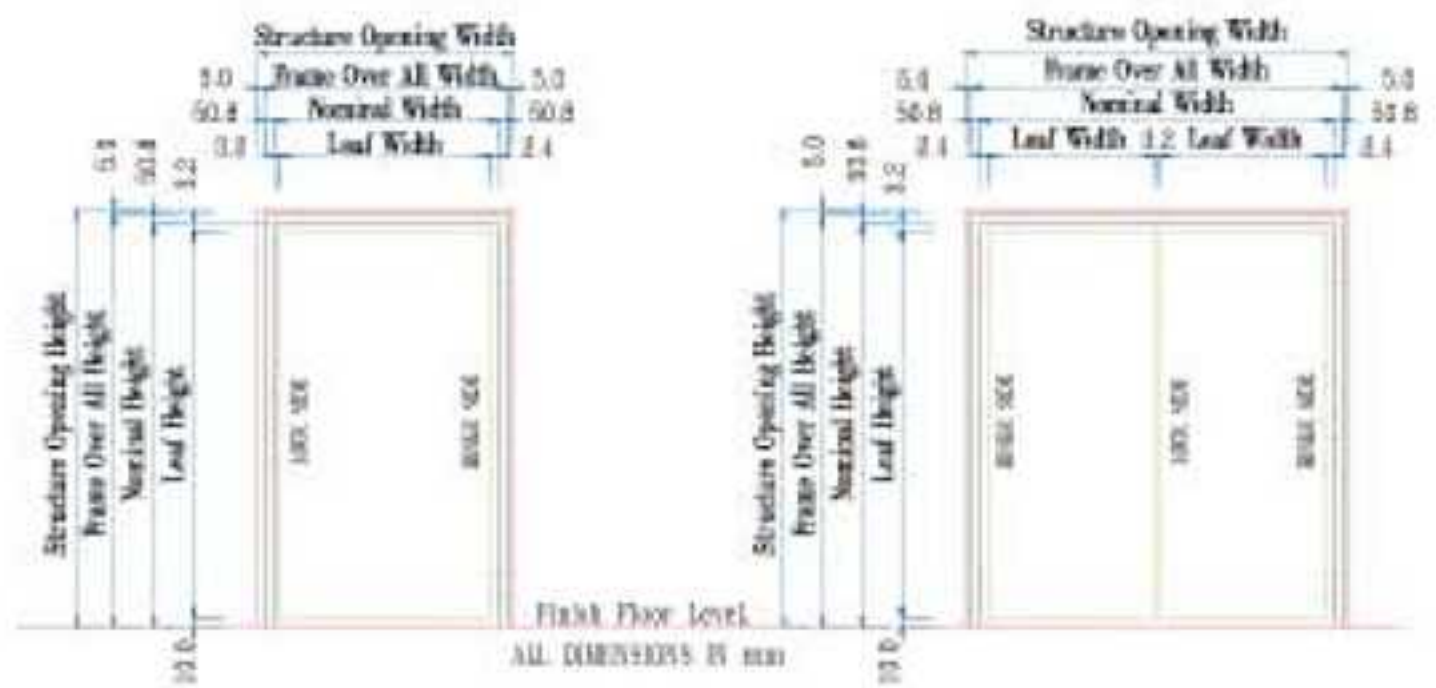

Hardware Locations

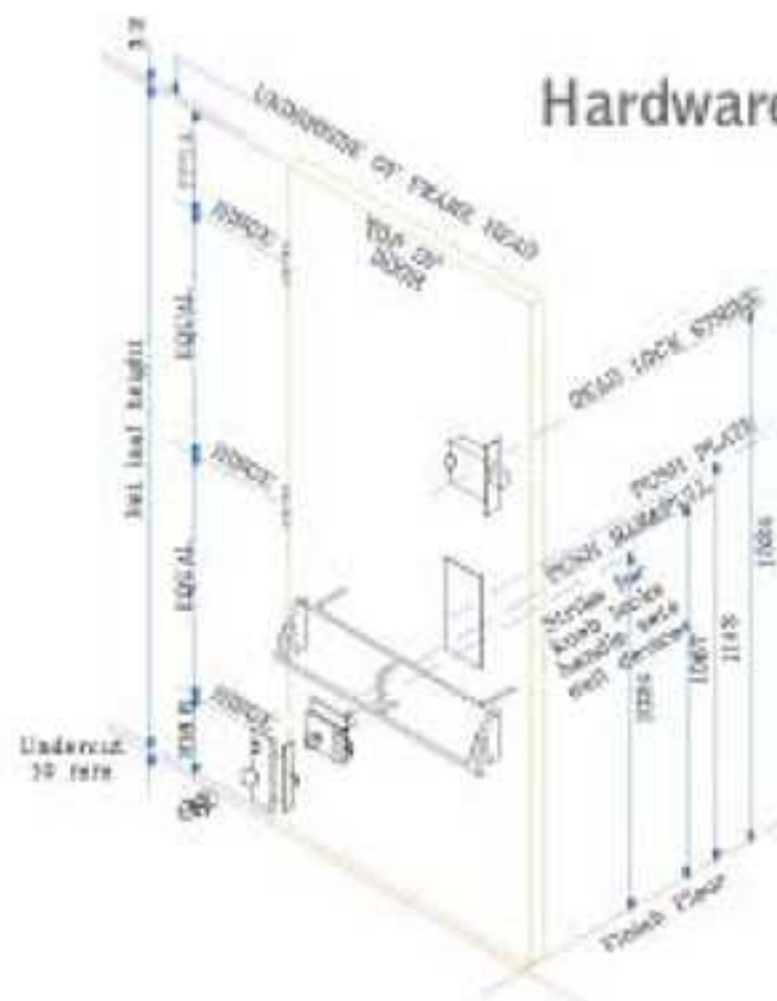

SARGENT
ASSA ABLOY

Corbin
RUSSWIN
ASSA ABLOY

Yale
Commercial Locks and Hardware

Ceco Door
ASSA ABLOY

CECO is a trademark of ASSA ABLOY Door Group, LLC
and is used under license by FRANCE METAL

France Metal Tech & sales:
9A Shafik Ghorbal St. - Roxy 11341 Cairo - Egypt.
Tel.: +202 22 56 4293 / +2012 2393 6430 Fax: +202 22 56 4294
E-mail : info@francemetal.net
Web Site : www.francemetal.net

France Metal Factory:
Block 111, Zone B3 10th of Ramadan City, - Egypt.
Tel.: +2015 372 416 / +2012 2393 6440 Fax: 2015 376 150
E-mail : mfc@francemetal.net

